

Free Flow Tee Joint



Technical Data

- GSI Free Flow Tees are designed and tested to surpass SMACNA Class 3 Leakage Standards.
- Pre-sealed with gasket made of EPDM rubber and proprietary co-polymer
- Zero VOCs
- Galvanized Steel (ASTM A653 and A924)
- Standard product is supplied in 26 GA, G-60 coating (ASTM A653 and ASTM A90)
- Available in Specialty Metals:
 - G-90 Galvanized Steel
 - Aluminum (ASTM B209 Alloy 3003 Temper H14)
 - 304 Stainless Steel (ASTM A480 2B Finish)
- Pressure Rating: Designed per SMACNA Third Edition 2005 Section 4.8 Figure 4-6 Branch Connections
- Dimensional Tolerance: $\pm 1/4"$

Product Availability

| Size (Ød)* | Gauge Availability | | Quantity | Dimension | | |
|------------|--------------------|--------|----------|--------------------|--------------------|--------------------|
| | 26 Ga. | 24 Ga. | | A | B | C |
| 4" | Yes | - | 20 | 6" | 5 $\frac{1}{4}$ " | 10 $\frac{1}{2}$ " |
| 5" | Yes | Yes | 15 | 6 $\frac{1}{2}$ " | 12 $\frac{1}{8}$ " | 14 $\frac{1}{8}$ " |
| 6" | Yes | Yes | 15 | 6 $\frac{1}{2}$ " | 6 $\frac{1}{2}$ " | 13" |
| 7" | Yes | Yes | 4 | 7 $\frac{1}{2}$ " | 7 $\frac{1}{4}$ " | 14 $\frac{1}{2}$ " |
| 8" | Yes | Yes | 8 | 8 $\frac{3}{8}$ " | 8 $\frac{1}{16}$ " | 15 $\frac{3}{4}$ " |
| 9" | Yes | Yes | 1 | 9" | 8 $\frac{3}{8}$ " | 16 $\frac{3}{4}$ " |
| 10" | Yes | Yes | 1 | 9 $\frac{3}{8}$ " | 10" | 20" |
| 12" | Yes | Yes | 1 | 10 $\frac{3}{4}$ " | 10 $\frac{3}{4}$ " | 21 $\frac{1}{2}$ " |
| 14" | Yes | Yes | 1 | 11 $\frac{1}{2}$ " | 12" | 24" |

* Standard 90° Tee Joint Sizes 3" and 14"-20" are available upon request.

A. Free Flow Tee Joints now come standard with sealed joints and a sealed riveted seam. Unsealed fittings are available upon request.

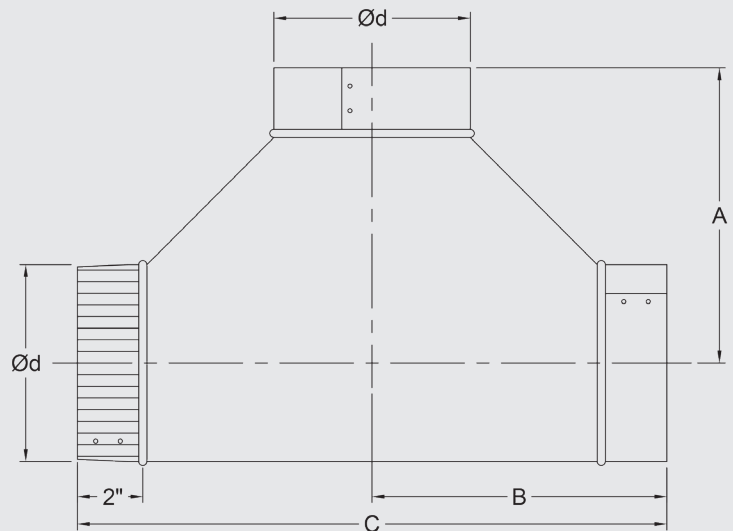

Part Number Schematic

Example: **FTJ10GA26**** = Free-Flow Tee Joint for 10" Pipe in 26Ga. Galvanized Steel

| FTJ | 10 | GA | 26 |
|---------------------|-------------------|---|--|
| Free-Flow Tee Joint | Tee Diameter (Ød) | Material GA - Galvanized (Std.) AL - Aluminum S4 - 304 S.S | Gauge GA - 28, 26, 24 AL - 32 S4 - 26 |

** Add 90 for G90 Galvanized Coating
Items in green denote other available features
Check with your sales representative for availability of any size, gauge, or specialty metal item not shown here.